

User manual

# OPTIMA 100



# Table of Contents

<b>Preface</b> .....	<b>iii</b>
About this Manual .....	iii
Safety and Handling Precautions .....	iv
Using this Menu .....	v
<b>Introduction</b> .....	<b>1</b>
System Requirements .....	1
Main Features .....	1
Package Contents .....	2
Camera Views .....	3
Camera Buttons .....	5
Navigation Control .....	5
Camera Memory .....	7
<b>Getting Started</b> .....	<b>8</b>
Attaching the Wrist Strap .....	8
Inserting the Battery .....	8
Inserting an SD/SDHC Memory Card .....	9
Charging the Battery .....	10
Turning the Power On and Off .....	10
Initial Settings .....	10
Modes .....	11
<b>Using the LCD Monitor</b> .....	<b>13</b>
LCD Monitor Layout .....	13
<b>Recording Photos, Videos and Voices</b> .....	<b>22</b>
Taking Photos .....	22
Using the Stabilizer .....	22
Setting the Zoom Control .....	23
Using Flash .....	24
Setting the Focus Mode .....	25
Using the Function Menu .....	26
Using the Record Menu .....	32

Recording Voices .....	53
<b>Playback .....</b>	<b>54</b>
Viewing in Single Navigation .....	54
Viewing thumbnails .....	54
Zooming images.....	56
Playing Movies .....	56
Playing Voice Recording .....	58
Playing Voice Memo .....	58
Deleting an Image/Video/Audio .....	59
Playback Menu .....	60
<b>Using the Setup Menu .....</b>	<b>76</b>
Setting Sounds.....	76
Setting Power Save.....	77
Setting LCD Save.....	77
Setting Date & Time .....	78
Setting Language .....	78
Setting File Numbering.....	78
Setting TV Out .....	79
Setting LCD Brightness .....	79
Setting Memory Kit.....	79
Reset All.....	80
<b>Making Connections .....</b>	<b>81</b>
Connecting the Camera to a TV.....	81
Connecting the Camera a PC .....	81
Connecting the Camera to a Printer.....	82
<b>Appendix .....</b>	<b>83</b>
About Folder and File Names .....	83
<b>Troubleshooting .....</b>	<b>84</b>
<b>Specifications .....</b>	<b>86</b>
Customer care .....	88

# Preface

## **About this Manual**

This manual is designed to assist you in using your new digital camera. All information presented is as accurate as possible but is subject to change without notice.

## **Copyright**

This manual contains proprietary information protected by copyright. All rights are reserved. No part of this manual may be reproduced by any mechanical, electronic or other means, in any form, without prior written permission of the manufacturer.

© Copyright 2009

## **Trademark Recognition**

Windows 98/2000/ME/XP are registered trademarks of Microsoft Corporation in the United States and/or other countries. Windows is an abbreviated term referring to the Microsoft Windows Operation System. YouTube is a brand of Google, Inc. and YouTube, LLC, Mountain View, California, US. All other companies or product names are trademarks or registered trademarks of their respective companies.

## **Safety and Handling Precautions**

### **Camera Information**

- Do not take apart or attempt to service the camera yourself.
- Do not expose the camera to moisture, or extreme temperatures.
- Allow the camera to warm up when moving from cold to warm temperatures.
- Do not touch the camera lens.
- Do not expose the lens to direct sunlight for extended periods.
- Do not use abrasive chemicals, cleaning solvents or strong detergents to clean the product. Wipe the product with a slightly damp soft cloth.



### **Battery Information**

- Turn off the camera before installing or removing the rechargeable battery.
- Use only the provided batteries or type of battery and charger that came with your camera. Using other types of battery or charger may damage the equipment and invalidate the warranty.
- When the camera is used for an extended period of time, it is normal for the camera body to feel warm.

- Download all pictures and remove the battery from the camera if you are going to store the camera for a long period of time.
- The type of battery and the battery power level may cause the lens to be stuck up. Ensure you use the correct battery type and use a fully charged battery.
- Risk of explosion if battery is replaced by an incorrect type. Dispose of used batteries according to the instructions.

## Using this Menu

Symbols used in this manual are explained below:

 <p>Note</p>	This indicates useful information when using your camera.
 <p>Warning</p>	This indicates warning message that should be read before using the function.



# Introduction

Congratulations on the purchase of your new digital camera. This manual provides step-by-step instructions on how to use your camera, and is intended for your reference only.

## System Requirements

In order to get the most out of your camera, your computer must meet the following system requirements:

### For Windows:

- Windows 2000/XP/Vista
- Processor: Pentium II 450MHz or above
- Memory: 512MB or above
- HDD space: 200 MB or above
- 16bit color display monitor
- Microsoft DirectX 9.0C
- USB port and CD-ROM drive

### For Macintosh:

- Power Mac G3 or later
- Mac OS 10.0-10.4
- Memory: 64MB or above
- HDD space: 110MB or above
- USB port and CD-ROM drive

## Main Features

- 10 mega pixels resolution
- Up to 3x optical zoom and 5x digital zoom
- 1/2.3 inch CCD image sensor
- 2.7 inch color LCD monitor
- 32MB internal flash memory with optional external SD/SDHC card
- Supports up to 4GB of SD card, and up to 32GB of SDHC card
- Sleek metallic finish
- Easy-to-use button interface
- DCF, DPOF, PictBridge compatibility



- Slideshow feature to review your pictures and movies
- A/V output to view your pictures and movies on your TV
- USB port to transfer photos and movies to your PC

## Package Contents

Please check the contents of your camera package. It should contain:

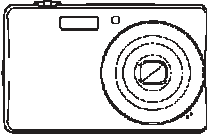

OPTIMA 100

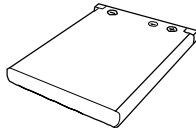

Li-ion battery



Battery charger  
(optional)



Wrist strap



USB cable

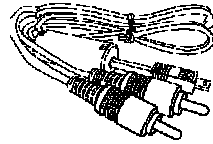

AV cable (optional)

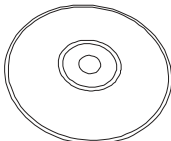

CD-ROM

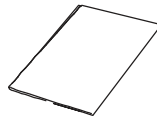

Quick Start Guide/  
User Manual (optional)



Camera pouch (optional)

# Camera Views

## Front View

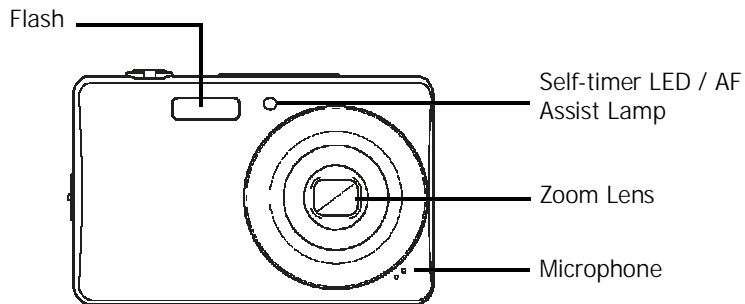

## Back View

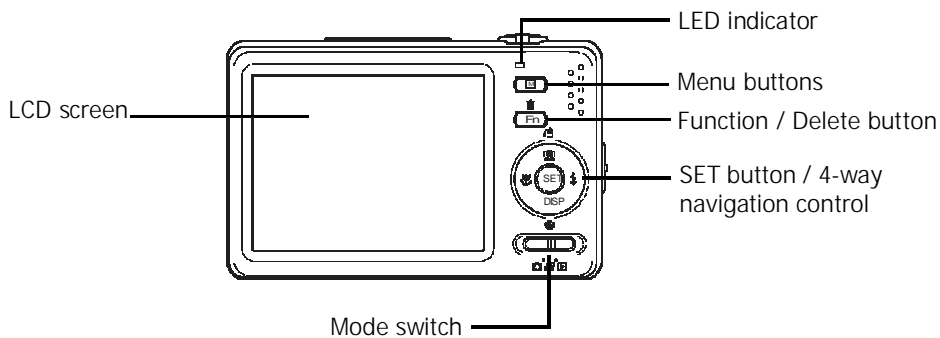

## Top View

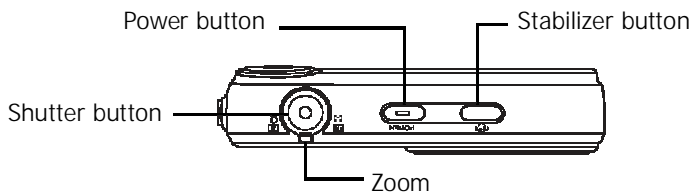

## Bottom View

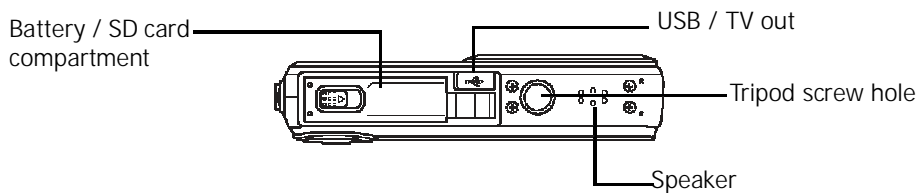

## Left/Right View

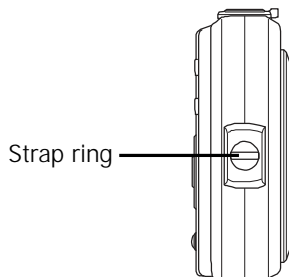

## Camera Buttons

Your camera is equipped with different buttons for ease of use.

Button	Description
Power	Press to turn on/off the power.
Stabilizer	The stabilizer sets the optimal ISO value according to light levels to compensate for camera shake. Press to set stabilizer on/off.
Shutter	Press to capture an image or start/stop recording video or audio clip.
Play	If the camera is turned off, press and hold to turn on camera in Playback mode. If the camera is turned on, press to toggle camera to Playback or Record mode.
Zoom	Slide the zoom control to change zoom focus.
Menu	Press to enter menu.
Function/ Delete	In Record mode, press to enter function menu. In Playback mode, press to delete an image, video or audio clip.

## Navigation Control

The 4-way **Navigation Control** and the **SET** button allows you to access the various menus available from the On Screen Display (OSD). You can configure a wide range of settings to ensure maximum results from your photos and videos. Further functions of these buttons are as follows:

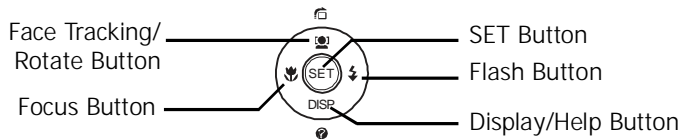

Button	Usage
SET	1. Confirm a selection when using the OSD menus.
Flash/ Right	<ol style="list-style-type: none"> <li>1. In Record mode, press to scroll through the flash mode options. (Auto, Anti Red-eye, Fill, Slow Sync and Off)</li> <li>2. In Playback mode, press to view the next image, video or audio clip.</li> <li>3. In Playback Video mode, press to fast forward video playback</li> <li>4. In Menu, press to enter the submenu or to navigate through the menu selections.</li> </ol>
Macro/ Left	<ol style="list-style-type: none"> <li>1. In Record mode, press to scroll through the focus mode options. (Macro, Pan Focus, Infinite, Normal)</li> <li>2. In Playback mode, press to view the previous image, video or audio clip.</li> <li>3. In Playback Video mode, press to retract video playback</li> <li>4. In Menu, press to exit a submenu or to navigate through the menu selections.</li> </ol>
Up/Face Tracking/ Rotate	<ol style="list-style-type: none"> <li>1. In Menu, press to navigate through the menu and submenu selections.</li> <li>2. In Record mode, press to turn the face tracking function on and off.</li> <li>3. In Playback Video/ Audio mode, press to Start/Pause video or audio playback.</li> <li>4. In Playback photo mode, press to rotate the image clockwise 90 degrees by each press of the button. This feature is applicable for still images only.</li> </ol>

Button	Usage
Display/Down/ Help	<ol style="list-style-type: none"> <li>1. In Photo, movie and Playback mode, press to change the LCD screen display to show or hide OSD icons or view Help.</li> <li>2. In Record mode, press to change LCD screen display to show or hide OSD icons and guide lines or Help.</li> <li>3. In Menu, press to navigate through the menu and submenu selections.</li> <li>4. In Playback Video/ Audio mode, press to stop video/audio playback.</li> </ol>

## Camera Memory

### Internal memory

Your camera is equipped with 32MB of internal memory. If there is no memory card inserted in the memory card slot, all images, videos and audio clips recorded are automatically stored in the internal memory.

### External storage

Your camera supports SD cards of up to 4GB in size. It also supports SDHC cards with a maximum capacity of 32GB. If there is a storage card inserted in the memory slot, the camera automatically saves all images, videos and audio clips in the external storage card. The icon  indicates the camera is using SD card.



Not all cards may be compatible with your camera. When purchasing a card, please check the card's specifications and take the camera with you.

# Getting Started

## Attaching the Wrist Strap

Follow these instructions to attach the wrist strap to your camera to facilitate easy carrying:

1. Insert the short loop of the strap in the strap eyelet.
2. Thread the larger loop of the strap through the short loop and pull tight to attach the strap to the camera.

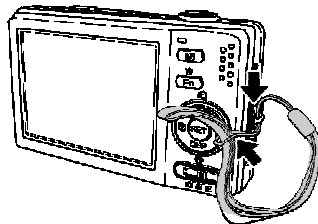

## Inserting the Battery

Follow these instructions to insert the battery into the battery compartment. Please read "Battery Information" on page iv before inserting/removing the battery.

1. Make sure the power is off before inserting the battery.
2. Open the battery compartment at the bottom of the camera.

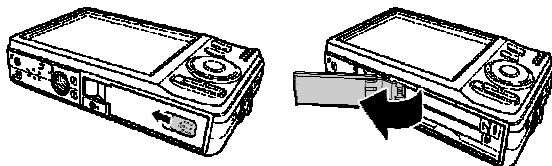

3. Insert the battery into the compartment with the terminal facing inside the camera.

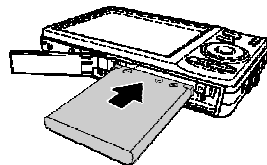

4. Close the battery compartment.

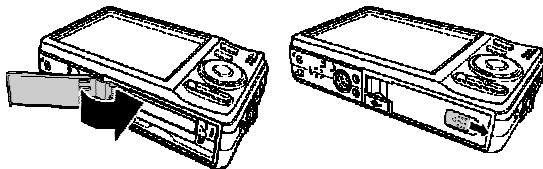

## Inserting an SD/SDHC Memory Card

Expand your camera's storage by using SD or SDHC memory cards.

1. Open the SD card compartment at the bottom of the camera.
2. Insert the SD/SDHC card into the memory card slot with the metallic part facing the front side of the camera.
3. Push the SD/SDHC card into the memory slot until it clicks into place.
4. Close the SD card compartment.

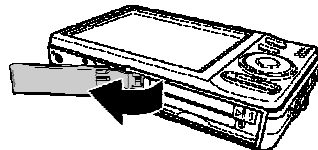
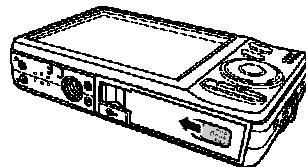

To remove the SD/SDHC card

1. Open the battery compartment.
2. Gently push the card until it pops out.
3. Pull out the card carefully.

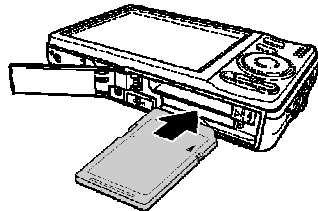



## Charging the Battery

The battery that comes along with your package is not charged. You need to charge the battery before using the camera.

1. Insert the battery into the battery charger as shown.
2. Connect the battery charger to the adaptor.
3. Plug the adaptor to the main outlet.

The battery charging time is 2 hours.

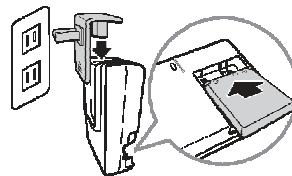

## Turning the Power On and Off

Press **POWER** to turn on/off the camera.

When turning on the camera, it may act depending on the switched mode:

- When the camera is switched to be Movie or Photo Record mode and you turn on the camera, the start-up image displays briefly and the start-up sound plays if enabled. The zoom lens extends as well.
- When the camera is switched to be Playback mode and you turn on the camera, it will enter Playback mode directly and the zoom lens will not extend.

See "Modes" on page 11 to know more about Record and Playback modes.

## Initial Settings

When you turn on your camera for the first time, you will be asked to do the initial settings of your camera.

When you turn the Power button on, the Language Menu is displayed on the LCD screen for you to setup the display language.

### Setting the Language

1. Press ▲ , ▼ , ◀ or ▶ to move through the selection.
2. Select a language, then press SET to apply.

## Setting the Date & Time

1. Press ◀ or ▶ to move through the selection.
  2. Press the ▲ or ▼ keys to change the value for the date and time.
  3. Press **SET** to apply.
  4. If necessary, press  to close the menu.
- Now, you are ready to start taking photos and videos.



**Holding down the ▲ or ▼ keys to change the values continuously.**

## Modes

Your camera has three modes:

### Photo Record mode

- Set to Photo Record mode to capture images and record audio clips.
- Record mode can be further set to mode options like auto, movie and scene selection modes. See "Selecting the Photo Record mode options" below.

### Movie Record mode

- Set to Movie Record mode to record videos.

### Playback mode



- Set your camera to Playback mode to view and edit captured images and playback videos and audio clips. You can also attach voice memo to images in this mode.

## Switching Between Modes

Adjust the Mode switch to switch among Photo Record, Movie Record, and Playback mode.

## Selecting the Photo Record mode options

Maximize the quality and ease of use of your camera by using the different mode options. The mode options allow you to capture images with preset settings according to scene conditions.

1. Set the camera to Photo Record mode.
2. Press  to launch Record Mode Menu.
3. Select **Record Mode**, then press  to enter submenu.
4. Select a mode.
5. Press the **SET** button to apply selected mode.

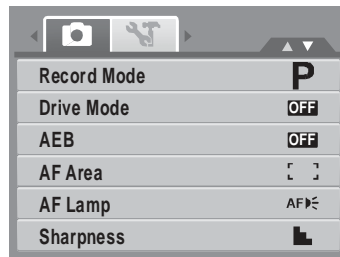

- For more information, see "Using the Record Menu" on page 32.
- Use the 4-way navigation control to move through the menu selections.

# Using the LCD Monitor

The high resolution 2.7" LCD monitor shows all important information regarding camera settings as well as the visual image of your photo or video. The display on the LCD monitor is called the On Screen Display or OSD.

## LCD Monitor Layout

The following illustrations show the LCD monitor layout and icon descriptions.

### Record Mode Screen Layout

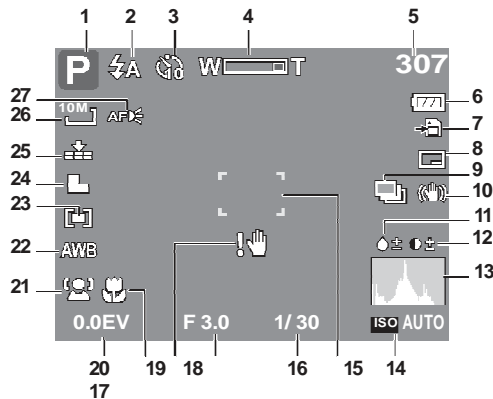

No.	Item	Description
1	Record Mode	Indicates the current mode.
2	Flash	Indicates flash settings.
3	Self-timer / Burst	Indicates drive mode settings.
4	Zoom indicator	Displays zoom.

No.	Item	Description
5	Shots remaining	Indicates the remaining shots available.
6	Battery	Indicates battery level.
7	Storage media	Indicates current storage media in use.
8	Date stamp	Indicates date stamp is enabled.
9	AEB	Indicates AEB function is enabled
10	Stabilizer	Indicates stabilizer function is enabled.
11	Saturation	Displays saturation settings.
12	Contrast	Displays contrast settings.
13	Histogram	Graphic display of light level for the current image.
14	ISO	Displays ISO settings.
15	Focus area	Use to frame subject to capture.
16	Shutter speed	Displays shutter speed settings.
17	Aperture value	Displays aperture settings.
18	Shake warning	Indicates that the camera is shaking.
19	Macro	Indicates macro is enabled.
20	Exposure	Displays exposure settings.
21	Face tracking	Indicates face tracking is enabled.

No.	Item	Description
22	White balance	Displays white balance settings.
23	Metering	Displays metering settings.
24	Sharpness	Displays sharpness settings.
25	Quality	Displays quality settings.
26	Resolution	Displays resolution settings.
27	AF lamp	Indicates AF lamp is enabled.

## Playback Mode Screen Layout

The Playback mode display varies depending on the type of image being viewed.

### Playback mode display of still images:

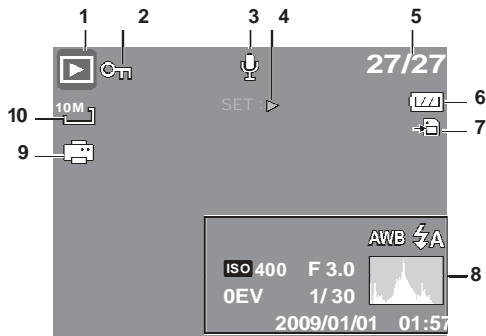

No.	Item	Description
1	Playback mode	Indicates playback mode.
2	Protect	Indicates file is protected.
3	Voice memo	Indicates voice memo is attached.
4	Button intro	Indicates the button to press on the camera to play a movie or audio file.
5	File no. / Total no.	Indicates the file number over the total number of files in the storage card.
6	Battery	Indicates battery level.

No.	Item	Description
7	Storage media	Indicates used storage memory.
8	Recording information	Displays recording information of the file.
9	DPOF	Indicates the file is marked for printing.
10	Resolution	Displays the resolution settings.

### Playback mode of videos:

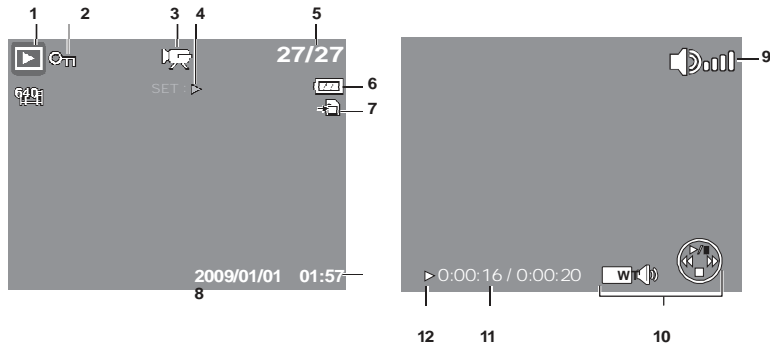

No.	Item	Description
1	Playback mode	Indicates playback mode.
2	Protect	Indicates file is protected.
3	Movie clip	Indicates the file is a movie.



No.	Item	Description
4	Button intro	Indicates the button to press on the camera to play a movie or audio file.
5	File no. / Total no.	Indicates the file number over the total number of files in the storage card.
6	Battery	Indicates battery level.
7	Storage media	Indicates used storage memory.
8	Recording information	Displays recording information of the file.
9	Volume	Indicates volume settings.
10	Key indicator	Indicates the buttons to press on the camera to apply the functions.
11	Played time	Indicates played time.
12	Playing status	Displays playing status.

## Playback mode of audio clips:

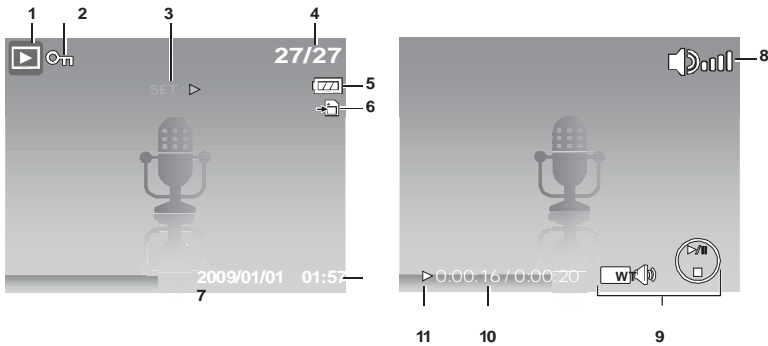

No.	Item	Description
1	Playback mode	Indicates playback mode.
2	Protect	Indicates the file is protected.
3	Button intro	Indicates the button to press on the camera to play a movie or audio file.
4	File no. / Total no.	Indicates the file number over the total number of files in the storage card.
5	Battery	Indicates battery level.
6	Storage media	Indicates used storage memory.
7	Recording information	Displays recording information of the file.
8	Volume	Indicates volume settings.

No.	Item	Description
9	Key indicator	Indicates the buttons to press on the camera to apply the functions.
10	Played time	Indicates played time.
11	Playing status	Displays playing status.

## Changing the LCD Monitor Display

The type of information displayed on the LCD screen can be changed using the ▼ button.

Press the ▼ button repeatedly to change the LCD display from one type to another.

In Photo / Video Record Mode, the LCD display can be changed into any of the following:

- OSD on
- Full OSD on
- Guide lines on
- OSD off
- Help



- The OSD information may vary depending on the record mode type.
- The following icons, if enabled, are still displayed on the LCD even when OSD off or Guide lines on: AEB, Face tracking, AF lamp, Drive mode, and Macro.
- Use the “Guide lines” to properly set image for capture.

In Playback mode, the LCD display can be changed into any of the following:

- Full OSD on
- OSD off
- Help



**Note**

LCD display cannot be changed in the following situations:

- Manual exposure mode
- Recording movie or audio clips
- Playing movie or audio clips
- Playing slideshow

# Recording Photos, Videos and Voices

## Taking Photos

Now that you are familiar with your camera, you are now ready to take your photos. Taking photos with your camera is very simple.

1. Turn on the camera by pressing the **Power** button.
2. Adjust the switch mode to **Photo Record**.
3. Frame the shot using the focus bracket on the LCD monitor. See illustration on the right.
4. Half press the **Shutter** button. The camera automatically adjusts the focus and exposure. When the camera is ready to take the photo, the frame bracket turns green, the shutter speed and aperture value are displayed.
5. Fully press the **Shutter** button to capture image.

When the shake warning icon  appears, hold the camera steadily, with your arms at your side or use a tripod to stabilize the camera to prevent blurred images.

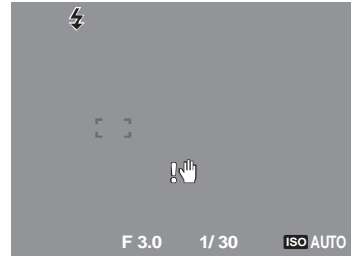

## Using the Stabilizer

The Stabilizer function prevents blurred images caused by shaking.



To activate Stabilizer

- Press the **Stabilizer** button on top of your camera to enable/disable stabilizer.

If Stabilizer is enabled, the stabilizer icon is displayed on the LCD monitor and the ISO setting is automatically set to Auto. See "ISO" on page 30 for more details.



Stabilizer  
on

## Setting the Zoom Control

Your camera features up to 3x optical zoom and up to 5x of digital zoom. Optical zoom is achieved by mechanically adjusting the lens. While digital zoom is activated through the menu settings. Please refer to "Setting the Digital Zoom" on page 48 on how to setup digital zoom.

To adjust the optical zoom:

1. Press the **Zoom** buttons to zoom in or zoom out an image.
2. The zoom indicator appears on the LCD monitor. 

### Zoom control

Slide left to zoom out.

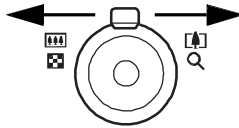

Slide right to zoom in.

To adjust the digital zoom:

1. Activate digital zoom. See "Setting the Digital Zoom" on page 48.
2. Slide the zoom control right to optically zoom in an image to its maximum until it stops.
3. Release the zoom control.

4. Slide the zoom control right again to switch to digital zoom automatically. Zooming continues. 

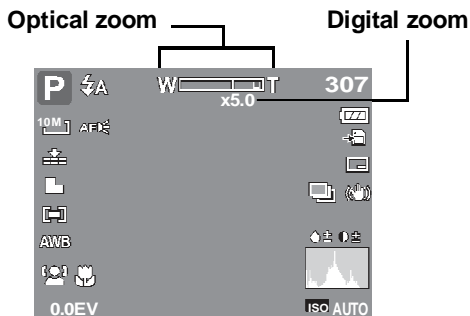

Digital zoom is not activated when recording movies.

## Using Flash

When taking pictures in difficult lighting conditions, use the **Flash** button to get correct exposure. This function cannot be activated in recording movies or continuous shooting.

To activate Flash:.

- Press the **Flash/Right** button on your camera repeatedly until your desired flash mode is displayed on the LCD monitor.

Your camera is equipped with five flash modes:

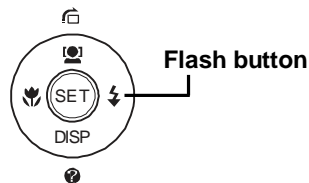

**Auto.** The flash fires automatically whenever extra lighting is needed.

**Red-eye reduction.** The flash fires twice to reduce the red-eye effect.

**Forced on.** The flash fires whenever you press the shutter button regardless of lighting conditions.

**Slow sync.** The flash fires with a slow shutter speed.

**Forced off.** The flash is turned off.



- Flash function is only available in shooting still images but not available in Burst and AEB modes.
- Do not charge the flash while pressing the zoom button. Charge the flash after releasing the zoom button if necessary.

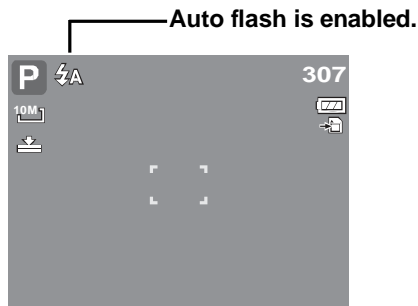

## Setting the Focus Mode

This function allows users to define the type focus when recording a still image or a movie clip.

To set the Focus mode

- Press the **Macro** button repeatedly until the desired focus mode icon is displayed on the lower left corner of the LCD monitor.

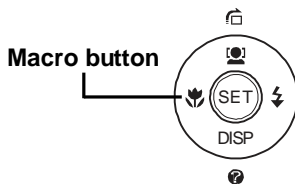



Your camera supports the four focus modes:

**Normal.** With normal focus, the focus range starts from 0.8m. When the camera is set to Normal mode, there is no icon displayed on the screen.



**Macro.** This mode is designed for close-up photography. If Macro is enabled, you can capture the detail and sharpness of a very close image by fixed focus.

**PF Pan Focus.** When Pan Focus is set, the camera focuses on every object.

**INF Infinity.** When Infinity is set, the camera focuses on distant objects.



**Macro enabled**

## Using the Function Menu

The **Function Menu** is used to adjust capture settings in Record Mode. It contains My Mode, Resolution, Quality, EV Compensation, White Balance, ISO, Metering, and Color Mode.



Press the **Fn** button of your camera to launch the Function Menu.



Press the **Fn** button again to close the menu.

- The Menu bar displays the current status of your camera settings. Only the available functions for the settings are shown as icon on the menu bar.
- The available options for each item on the menu bar are shown in the Menu options.
- Use the ◀ or ▶ key to move through the menu selections then press the **SET** button to save and apply changes.

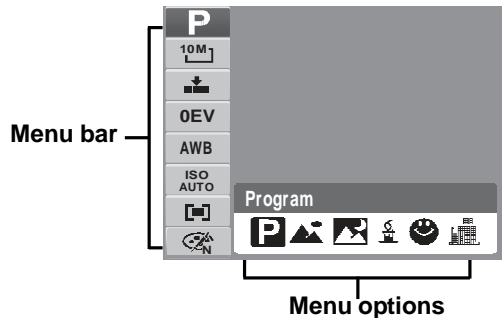

## My Mode

The My Mode function displays the 6 most recent modes used in order. When you move through the different modes in the menu options, the items on the menu bar changes synchronously to the corresponding available settings.

## Resolution

The Resolution function is used to set the resolution before you capture the image. Changing the resolution affects the number of images that can be stored in your memory card. The higher the resolution, the more memory space is required.

The table below shows the resolution values for still images.

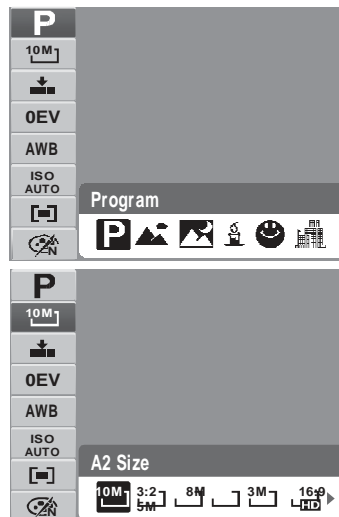

Icon	Pixel Size	Print Size Suggestion
	3648 x 2736	A2 Size
<b>3:2</b>	3648 x 2432	A2 Size
	3264 x 2448	A3 Size
<b>5M</b>	2592 x 1944	A4 Size

Icon	Pixel Size	Print Size Suggestion
	2048 x 1536	4" x 6"
	1920 x 1080	HDTV
	640 x 480	E-mail

## Quality

The Quality function lets you adjust the quality settings of your photos before you capture them. The quality determines the amount of compression applied to your photos. More compression results in a more detailed image. However, the higher the quality, the more memory space is required in your memory card.



## EV Compensation

EV stands for Exposure Value. In difficult lighting condition, the auto exposure function of your camera may be misled into giving the wrong readings. The EV Compensation function allows you to adjust the exposure value and correctly expose your images. Available for still images only.

- To adjust EV settings, press the ◀ or ▶ keys to increase/decrease the value. As you adjust the settings, the LCD monitor synchronously displays the image applying the EV settings. Press the **SET** button to save and apply changes.
- The available settings are: 0EV, +0.3EV, +0.7EV, +1.0EV, +1.3EV, +1.7EV, +2.0EV, -0.3EV, -0.7EV, -1.0EV, -1.3EV, -1.7EV, -2.0EV.

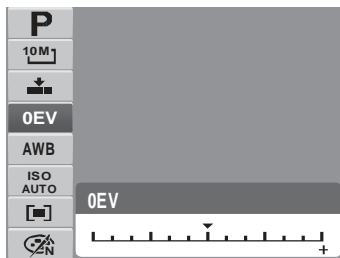





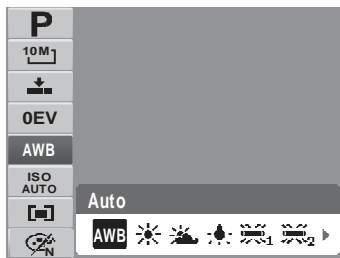

## White Balance

The White Balance function allows you to adjust the camera setting according to the white light when recording still images and movies.

- As you move through the selection, you can see the preview on the LCD monitor synchronously.



Icon	Item	Description
<b>AWB</b>	Auto	The camera automatically adjusts the white balance.
	Daylight	Ideally used for bright sunny conditions.
	Cloudy	Ideally used for cloudy conditions.
	Tungsten	Ideally used for indoor photos with tungsten or halogen lighting without a flash.
	Flourescent 1	Ideally used for indoor photos with reddish fluorescent lighting conditions.
	Flourescent 2	Ideally used for indoor photos with bluish fluorescent lighting conditions.
	Custom	Used when light source cannot be specified. Press the shutter button for the camera to automatically adjust the appropriate white balance setting according to the environment.

## ISO

The ISO function lets you adjust the ISO sensitivity in recording still images depending on the lighting levels of your surroundings.

- Use a higher ISO setting in dim conditions and a lower ISO setting in brighter conditions.
- As you move through the selections, the preview on the LCD monitor changes synchronously.
- Available settings are: Auto/100/200/400/800/ 1600/ 3200(3M, 16:9<2M>, VGA)/6400(1024 x 760).

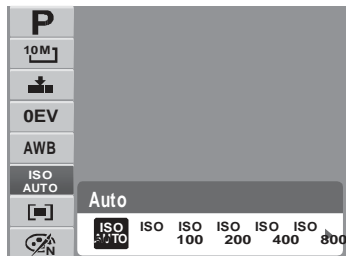



If the Stabilizer is enabled, ISO is automatically set to Auto and cannot be adjusted. To adjust ISO, disable Stabilizer first.

## Metering

The Metering function lets you select the area of the subject or frame by which the camera measures light to record still images or movies.

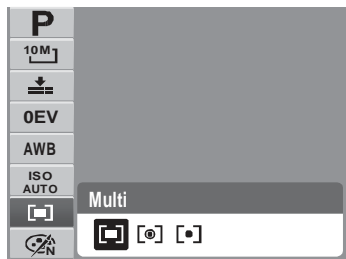
- As you move through the selection, the preview on the LCD monitor changes synchronously.



Icon	Item	Description
	Multi	The camera measures the exposure readings from multiple points in the subject area.
	Center	The camera measures the average light from the entire frame but gives more importance to the values near the center.





Icon	Item	Description
	Spot	The camera selects the exposure value based on the center of your picture.

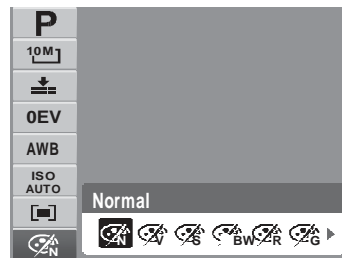

## Color Mode

The Color Mode function lets you record still images or movies and apply different colors or tones for a more artistic effect.

- As you move through the selection, the preview on the LCD monitor changes synchronously.



Icon	Item	Description
	Normal	The camera records normally.
	Vivid	The camera captures the image with more contrast and saturation emphasizing on the bold colors.
	Sepia	Images are captured in sepia tones.
	B&W	Images are captured in black and white.

Icon	Item	Description
	Vivid Red	Captured image becomes reddish. Ideally used to record images like flowers and cars to make them more vivid.
	Vivid Green	Captured image becomes greenish. Ideally used to record images like mountains and lawns to make them more vivid.
	Vivid Blue	Captured image becomes bluish. Ideally used to record images like the sky and the ocean, to make them look more vivid.

## Using the Record Menu



If you are in Record mode, you can access the Record menu simply by pressing the **MENU** button on your camera.

When the menu is displayed, use the 4-way navigation control and the **SET** button to move through menu selections and apply your desired settings. To close the menu anytime, press the menu button again.

## Record Menu

The Record menu allows you to change modes, and setup other capture settings.

To go to Record Menu:

Set the camera to Photo Record mode. See “Switching Between Modes” on page 11.

1. Press  to launch the Record Menu.
2. Use the ▲ or ▼ keys to move through the menu selections.
3. To select an item, press ►.
4. Change the submenu settings using the 4-way navigation control.
5. Press the **SET** button to save and apply settings.

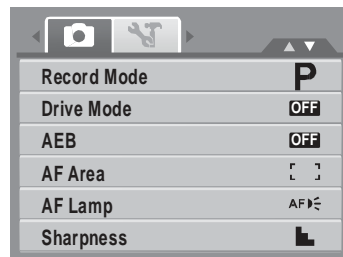

## Setting the Scene Mode

Setting the Scene mode allows you to capture images with preset settings according to the scenes or environment.





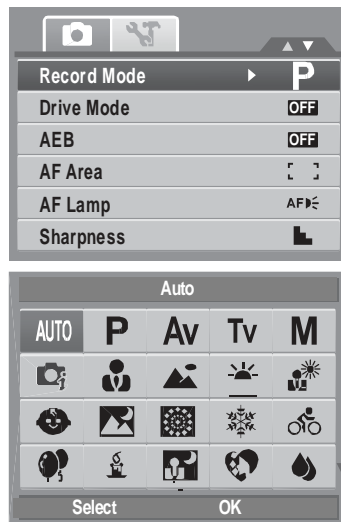



1. From the Record Menu, press **▶** to select **Record Mode**.
2. Use the navigation controls to move through the selection.
3. Press the **SET** button to save and apply changes.









The table below shows the available scene mode settings.











Icon	Item	Description
<b>AUTO</b>	Auto	The simplest way to shoot basic images. Settings are adjusted automatically.
<b>P</b>	Program	The camera automatically adjusts suitable shooting settings like shutter speed and aperture values.
<b>Av</b>	Aperture Priority	This feature lets users to adjust the aperture value and the camera automatically selects the shutter speed to match the brightness. See “Using Aperture Priority Mode” on page 42.



Icon	Item	Description
	Shutter Priority	This feature lets users to adjust the shutter speed and the camera automatically selects the aperture value to match the brightness.
	Manual Exposure	This feature lets users to adjust the shutter speed and aperture value to correctly expose your images.
	Intelligent Scene	The camera detects the shooting conditions and automatically switches to the appropriate scene mode. See “Using Intelligent Scene Mode” on page 38.
	Portrait	The camera blurs the background to focus on the subject.
	Landscape	This feature is used to emphasize wide scenic views.
	Sunset	This feature enhances the red hue for recording sunset images.
	Backlight	This feature is used to capture the image of a backlight object by changing the metering.
	Kids	This feature is used to capture still images of moving kids.
	Night Scene	This feature is used to capture images with night scenery background.

Icon	Item	Description
	Fireworks	This feature slows shutter speed to capture fireworks explosions.
	Snow	This feature is used for beach and snow scenes.
	Sports	This feature captures still images in high speed motions.
	Party	This feature is used for wedding or indoor party settings.
	Candlelight	This feature is used to capture warm candle light effects.
	Night Portrait	This feature is used to capture portrait pictures with night or dark background.
	Soft Skin	This feature enhances skin tone thus facial skin appears smooth.
	Soft Flowing Water	This feature enhances smooth effects like water or silk.
	Food	This feature is used to capture food images. The increased saturation in this mode makes the captured image more enticing.

Icon	Item	Description
	Building	This feature enhances the edges of captured images.
	Text	This feature enhances the black and white contrast normally used when capturing text images.
	Auction	Pictures taken in Auction mode are automatically saved under a specific folder named “_AUCTION”. See “Folder Structure” on page 83 for more information.
	Smile Capture	This feature uses face tracking to auto detect faces to capture. When smiles are detected, it continuously captures the image. See “Using Smile Capture Mode” on page 37.
	Blink Detection	This feature detects if the subject blinked an eye when the image is captured and gives the user an option whether to save it or not. See “Using Blink Detection Mode” on page 41.
	Pre-composition	This feature captures an image temporarily as a reference. Full press shutter after referring the subject to the reference point.
	Love Portrait	This feature uses face tracking to auto detect faces to capture portraits photos without the help of others. When over two faces are detected, AF is automatically activated. The camera starts count down and captures a picture in two seconds.
	Voice REC	This mode is used to record audio clips.

After selecting the scene mode, the selected mode, except Voice Rec, will be added to the forefront in MyMode of Function Menu. See “Using the Function Menu” on page 26.

## Using Smile Capture Mode

The Smile Capture mode uses smile tracking to automatically capture images. This feature is most useful in capturing different angles and smiles of moving people. When capturing an image with more than one person, the camera detects the smile of the closest person on the center of the screen.

To activate Smile Capture

1. Select  from the Scene Mode submenu.
2. Focus the camera on the subject to capture.
3. The smile capture icon blinks every second and the white focus frame turns green to denote camera activity.
4. When a smile is detected, the camera will automatically take a shot of the image.

**The camera displays a white frame when a face is detected.**



When capturing an image with several faces, face tracking function may take up more time tracking faces for the first time.

## Using Intelligent Scene Mode

With the Intelligent Scene Mode, the camera automatically detects the shooting conditions and switches to the appropriate scene and settings when aiming on a subject. This feature is most useful for novice users to capture great images even without basic knowledge of photography.

**Intelligent scene icon. After the camera detects the shooting conditions, this icon changes to show the detected scene mode.**

**Face tracking is automatically enabled.**



To activate Intelligent Scene

1. Select  from the Scene Mode submenu.
2. Focus the camera on the subject to capture.
3. The camera detects the shooting conditions and switches to an appropriate scene mode.
4. Half press the shutter button to focus the subject. The frame turns green to indicate focus is set.
5. Press the shutter button to take the shot.

**The camera displays a solid white frame when a face is detected.**







When Intelligent Scene function is enabled, icons will be displayed even in Guideline, None Display modes and when the shutter button is half pressed.

The table below shows the modes supported by Intelligent scene:

Icon	Intelligent Scene Modes	Description
	Portrait	This mode is set when a face is detected.
	Landscape	This mode is set when: <ul style="list-style-type: none"><li>• There is no face detected.</li><li>• The focus distance is more than 1.5 meters.</li><li>• The EV setting is greater than 11 or 10.5.</li></ul>
	Sunset	This mode is automatically set when sunset lighting is detected.
	Macro	This mode is set when: <ul style="list-style-type: none"><li>• There is no face detected</li><li>• The focus distance is within the macro range.</li></ul> This mode can only be detected when you half press the shutter button.
	Backlight	This mode is set when the EV setting greater than 2.5.
	Backlight Portrait	This mode is set when a face is detected with an EV setting greater than 2.5.

Icon	Intelligent Scene Modes	Description
	Night Scene	<p>This mode is set when:</p> <ul style="list-style-type: none"> <li>• There is no face detected.</li> <li>• The focus distance is more than 1.5 meters.</li> <li>• The EV setting is lower than 5 or 4.5.</li> </ul>
	Night Portrait	<p>This mode is set when a face is detected with an EV setting lower than 5 or 4.5.</p>

## Using Blink Detection Mode

The Blink Detection mode tracks faces and determines captured image that contain subjects with blinked eyes. After shooting, when the camera detects that the subject blinked an eye, a menu selection appears to ask the user whether to save the image or not. This feature saves time in managing photos to be stored or deleted from the memory.

To activate Blink Detection

1. Select  from the Scene Mode submenu.

Face tracking is automatically enabled.



Detected faces are framed.

2. Half press the shutter button to focus the subject. The frame turns green to indicate focus is set.
3. Press the shutter button to capture the image. The image is automatically saved unless the camera detects that the subject blinked an eye. In this case, the screen on the right is displayed:
4. Select **Save Image** to save or **Cancel** to disregard.





## Using Aperture Priority Mode

With Aperture Priority mode, users can adjust the aperture value and the camera automatically sets the shutter speed to match the brightness.

To activate Aperture Priority

1. Select **Av** from the Scene Mode submenu.
2. Press **SET** button to enter the adjust mode.
3. Use the **▲** or **▼** keys to select the aperture value options.
4. Press the shutter button to capture the image.



Displays the aperture value

## Using Shutter Priority Mode

With Shutter Priority mode, users can adjust the shutter speed and the camera automatically sets the aperture value to match the brightness.

To activate Shutter Priority

1. Select **Tv** from the Scene Mode submenu.
2. Press **SET** button to enter the adjust mode.
3. Use the **◀** or **▶** keys to select the shutter speed options.
4. Press the shutter button to capture the image.

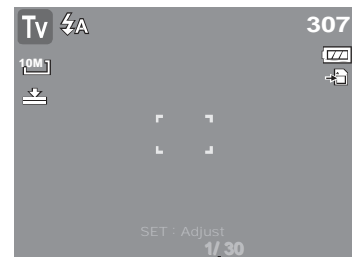

Displays the shutter speed value

## Using Manual Exposure Mode

With Manual Exposure mode, users can manually adjust the shutter speed and the aperture value.

To activate Manual Exposure

1. Select **M** from the Scene Mode submenu.
2. Press **SET** button to enter the adjust mode.
3. Use the ◀ or ▶ keys to select the shutter speed options or Use the ▲ or ▼ keys to select the aperture value options.
4. Use the ▲ or ▼ keys to increase or decrease the aperture or shutter speed values.
5. Use the **SET** button to switch between aperture and shutter speed adjustment and vice versa.
6. Press the shutter button to capture the image.



When you half press the shutter button, the difference between the correct and selected exposure is displayed in red.



Displays the aperture and shutter speed value

## Setting the Drive Mode



Your camera features a Self-timer and Burst which can be set in the Drive mode function in the Record Menu. The Self-timer allows you to take photos after a pre-defined delay. While burst lets you take consecutive shots. This function is only available in recording still images. The Drive mode setting is automatically set to off when you turn off the camera.

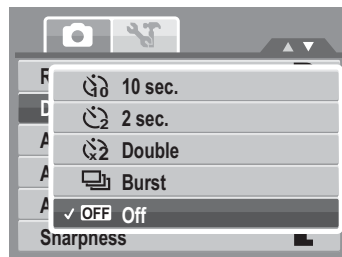
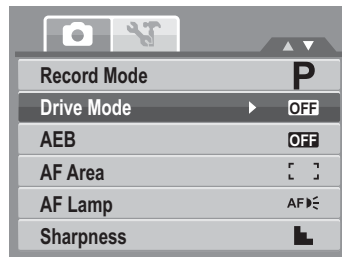

To set the Drive Mode

1. From the Record menu, select **Drive Mode**.
2. Use the ▲ or ▼ keys to go through the selection.
3. Press the **SET** button to save and apply changes.

The table below shows the available Drive mode settings.



Icon	Item	Description
	10 Sec Self-timer	Sets a 10-second delay to capture image after pressing the shutter button.
	2 Sec Self-timer	Sets a 2-second delay to capture image after pressing the shutter button.

Icon	Item	Description
	Double Self-timer	Performs delay and capture twice: <ul style="list-style-type: none"> <li>• Performs a 10-second delay, then captures the image.</li> <li>• Performs another 2-second delay then captures the image again.</li> </ul>
	Burst	Performs continuous shooting when the shutter button is pressed. Stops shooting when the shutter button is released.
	Off	Captures an image without time delay.

## Setting the AEB

AEB stands for Automatic Exposure Bracketing. This feature captures the same image with 3 different exposure settings.

- The settings are recorded in the following order: standard exposure, under exposure, and over exposure.

To set AEB

1. From the Record menu, select **AEB**.
2. Use the ▲ or ▼ keys to go through the selection.
3. Press the **SET** button to save and apply changes.

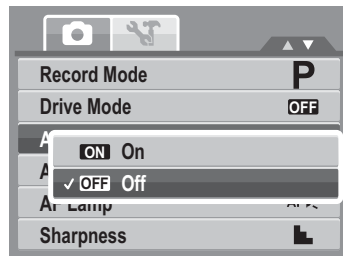

## Setting the AF Area



AF stands for Automatic Focus. This feature determines the area on which the camera focuses.

To set AF Area

1. From the Record menu, select **AF Area**.
2. Use the ▲ or ▼ keys to go through the selection.
3. Press the **SET** button to save and apply changes.

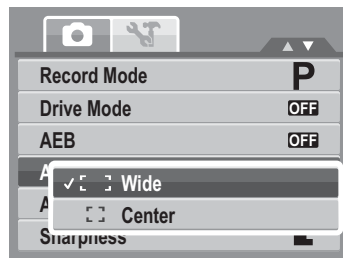
The table below shows the available AF area settings.



Icon	Item	Description
	Wide	The camera automatically selects focus area within the wide frame.
	Center	The focus area is fixed on the center.

## Setting the AF Lamp

The AF Lamp function allows you to record images even in low light conditions.

If AF Lamp is set to Auto, the AF lamp located in the front of the camera, see “Front View” on page 3, emits a red light by half pressing the shutter button allowing the camera to focus easily.

To set AF Lamp

1. From the Record menu, select **AF Lamp**.
2. Use the ▲ or ▼ keys to go through the selection.
3. Press the **SET** button to save and apply changes.

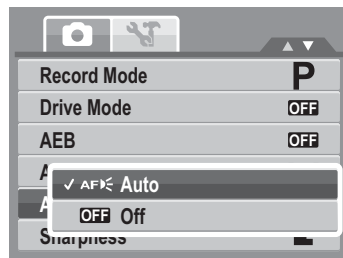

## Setting Sharpness

This function allows you to enhance or soften finer details of your photos.

To set Sharpness

1. From the Record menu, select **Sharpness**.
2. Use the ▲ or ▼ keys to go through the selection.
3. Press the **SET** button to save and apply changes.

The table below shows the available Sharpness settings.

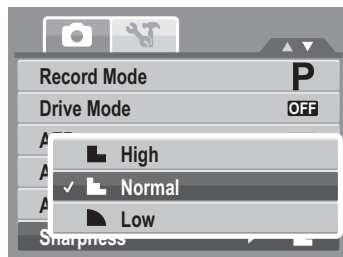

Icon	Item	Description
	High	Sharpens the image.
	Normal	Normal sharpness.
	Low	Softens the image.

## Setting Saturation

The Saturation function lets you adjust the color saturation in your photos. Use a higher saturation setting for rich colors and a lower saturation setting for more natural tones.

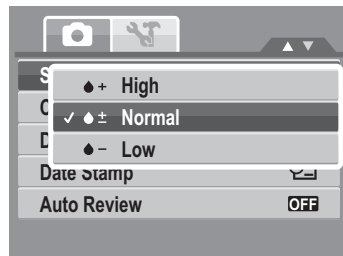

To set Saturation

1. From the Record menu, select **Saturation**.
2. Use the ▲ or ▼ keys to go through the selection.



2. Use the ▲ or ▼ keys to go through the selection.
3. Press the **SET** button to save and apply changes.

The table below shows the available Digital Zoom settings.

Icon	Item	Description
	Intelligent Zoom	Enlarges the image digitally with almost no distortion. This feature is available for still images only.
	Standard Zoom	Enlarges all image sizes up to a maximum of 5x in playback, but the image quality deteriorates.
	Off	Uses the optical zoom only.



- Digital Zoom is not available in Smile Capture, Video, and Voice Recording modes.
- The maximum Intellect zoom scale varies depending on the image type and resolution.

## Setting the Date Stamp

The Date Stamp function allows you to add the recorded date and time on your photos.

The recording date and time are based on your camera's clock settings. Once date and time are stamped on a photo, they can no longer be edited or deleted.

Limitations of Date Stamp functions are as follows:

- Available for still images only.
- May slow down AEB/ continuous shooting when Date Stamp is enabled in /AEB/ Burst mode.
- In vertical or rotated images, the date and time on your photos still appear horizontally.

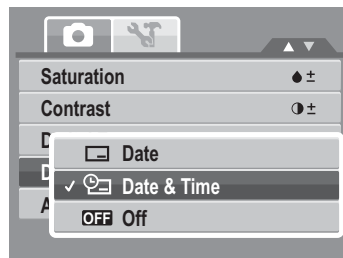

To set Date Stamp

1. From the Record menu, select **Date Stamp**.
2. Use the ▲ or ▼ keys to go through the selection.
3. Press the **SET** button to save and apply changes.

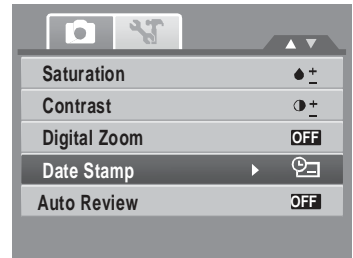

## Setting Auto Review

The Auto Review function lets you view the captured image right after shooting it.

If Auto review is On, the camera will display the captured image for 1 second on the LCD monitor.

To set Auto Review

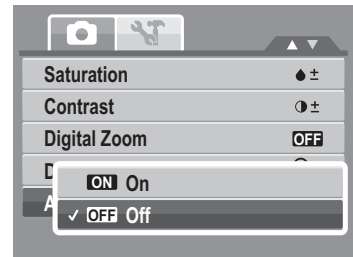
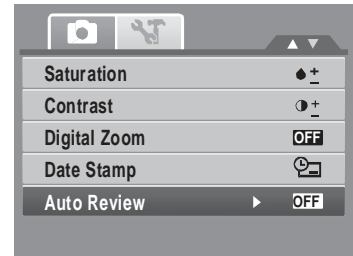

1. From the Record menu, select **Auto Review**.
2. Use the ▲ or ▼ keys to go through the selection.
3. Press the **SET** button to save and apply changes.







## Recording Movies

You can record movies with the camera, the available recording time depends on the capacity of the memory card. Movies can be recorded until the maximum memory capacity has been reached. However the length of a single movie may be limited (the limitation depends on the camera model).

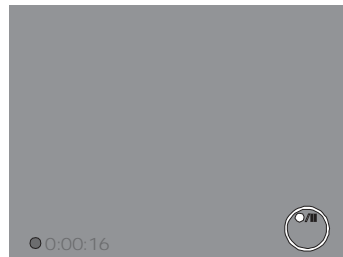
1. Adjust the switch mode to **Movie Record**.
2. Focus your camera on the subject that you want to take.
3. Press the Shutter button to start recording.
4. Use the  control to zoom in and zoom out an image.
5. To pause recording, press the  key.
6. To continue recording, press the  key again.
7. To stop recording, press the **Shutter** button.







- When the maximum capacity for a single video has been reached, simply press the shutter button again to continue recording.
- The camera will automatically stop recording when the memory capacity is full.
- Digital zoom is not available in movie recording.
- Sound cannot be recorded while pressing the  control.
- Power save is not available in movie recording or pause recording.

## Setting the Movie Size

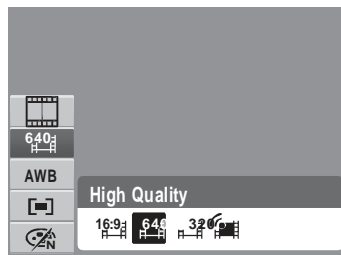
The Movie Size function icon appears only in Movie Mode. Use this function to adjust the resolution and quality of movie clips.

The table below shows the available size and corresponding image quality settings.



Icon	Frame Size	Image Quality
	720 x 400	HDTV
	640 X 480	High Quality
	320 x 240	Normal
	640 x 480	For Internet, see “Internet Mode” on page 52 below.

To set other movie mode settings, please refer to “Using the Function Menu” on page 26.

## Internet Mode

The Internet Mode allows you to record movies with predefined video settings for easy upload to the Internet website.

The Internet supports two file upload standards:

- Single File Uploader. The maximum movie file size is up to 100 MB.
- Internet Uploader. The maximum movie file size is up to 1 GB.

Most uploaded movie length ranges within 5 minutes.

Therefore when you record using the YouTube® mode, the following standards are followed:

- Recorded movies are set to Internet standard resolution of 640 X 480.
- Recording automatically stops when the file reaches 100 MB.

Recorded movies in the Internet mode are stored following the DCF rule, however movies are saved in a specific folder named “\_UTUBE”. For more details, please refer to “Folder Structure” on page 83.

- To record a YouTube® movie, select  from the Movie Size function.

Available recording time for a YouTube® movie is up to 10 minutes.

## Recording Voices

1. From the Record mode menu, select **Voice**. The Voice Recording screen layout is displayed on the LCD monitor.
2. Press the **Shutter** button to start recording.
3. Press the **Shutter** button again to stop recording.



Voice recording will automatically stop when the maximum memory capacity is full.

# Playback

View images, videos and audio clips through your camera's Playback mode.

## Viewing in Single Navigation

The Single navigation mode displays the image one by one on the LCD monitor. To view images/videos/audio clips, follow the steps below.

1. Adjust the Mode switch  to set or turn on the camera to Playback mode.
2. The LCD monitor displays an image. To understand the icons and other information on the screen, please see "Record Mode Screen Layout" on page 13.



3. Use the ◀ or ▶ keys to view next/previous image/video/audio.
4. To play a movie or audio clip, press the ▲ key. See "Playing Movies" on page 56 and "Playing Voice Recording" on page 58 for more details.

## Viewing thumbnails

1. Slide the zoom control left to view 9-image thumbnails.
2. Use the navigation controls to move through the items.

3. Press the **SET** button to select the image and view it normally.

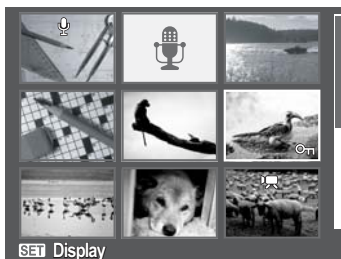

**Scroll bar.** If scroll bars appear, it indicates that the screen can be scrolled.

**Thumbnail view**

### Thumbnail icons

When you view the thumbnails, some images may contain icons. These icons indicate the type of file or recording.

Icons	Type	Description
	Voice Memo	Indicates that a voice memo is attached to the image.
	Movie	Indicates a recorded movie. The image displayed is the first frame of the movie clip.
	Locked File	Indicates that the image has been locked. Locked files cannot be edited or deleted.
	Voice Record	Indicates a voice recording file.

Icons	Type	Description
	File Error	Indicates an error file.

## Zooming images

The zoom view function works with still images only.

- In normal view, slide the zoom control right repeatedly until the desired zoom view.
- The 4 arrows on the LCD monitor indicate that the image is zoomed in.
- You can zoom view an image of up to 12X.
- Use the navigation controls to view the zoomed image.
- Press the **Menu**  button to close zoom view.









For 320 x 240 resolution images, you can only zoom in up to 6X.

## Playing Movies

1. Set the camera to Playback mode.
2. Use the navigation controls to scroll through the saved images. A movie clip has a movie icon displayed on screen. See picture on the left.
3. Press the **SET** button to play the movie.
4. During playback, press the ◀ or ▶ keys to fast forward or rewind the movie. The camera supports forward and rewind speed of up to 4x.



5. During playback, use  to control volume. Slide the zoom control left/right to decrease/increase volume.
6. Press the  key to pause playback. Press the  key again to resume. When paused, the play info will remain on screen.
7. To forward or rewind the movie frame by frame, press the  key to pause playback, then press the  or  keys.
8. Press the  key to stop the playback. The LCD monitor displays the movie frame image in Single navigation mode.



- The play info is displayed when the movie is paused or during REW/FF or frame by frame modes.
- Volume cannot be adjusted when paused or during REW/FF modes.





## To capture screenshot image from a movie clip

1. During playback of movie, press the  key to pause playback on your desired movie frame to capture.
2. Press the **Shutter** button to capture screenshot.
3. The camera will automatically stop playback. The LCD monitor displays the captured image in Single navigation mode.



This feature does not function when the memory card is full or the folder cannot be created. The  icon does not appear on the screen either.

## Playing Voice Recording

1. Set the camera to Playback mode.
2. Use the navigation controls to scroll through the saved images. When viewing a voice recording file, the LCD monitor displays the screen layout of Audio clips. See picture on the right.
3. Press the **SET** button to play the voice recording.
4. During playback, use the  to control volume. The volume icon appears on the screen. Slide the zoom control left/right to decrease/increase volume.
5. Press the  key to pause playback. Press the  key again to resume. When paused, the play info will remain on screen.
6. Press the  key to stop the playback. The LCD monitor displays the image in Single navigation mode.



Volume cannot be adjusted during pause or REW/FF modes.



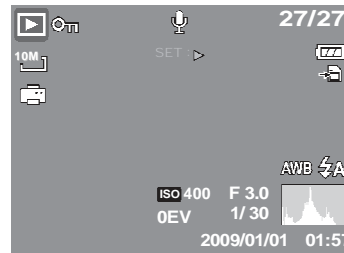

## Playing Voice Memo

Voice memo is separately recorded and attached to a captured image. See “Voice Memo” on page 68 on how to record voice memo.

1. Set the camera to Playback mode.
2. Use the navigation controls to scroll through the saved images. An image file with voice memo has a voice memo icon located on the top center of the LCD monitor. See picture on the right.
3. Press the **SET** button to play the voice recording.





4. During playback, use the  to control volume. Slide the zoom control left/right to decrease/increase volume.
5. Press the  key to pause playback. Press the  key again to resume. When paused, the play info will remain on screen.
6. Press the  key to stop the playback. The LCD monitor displays the image in Single navigation mode.



Volume cannot be adjusted when you pause the voice memo.

## Deleting an Image/Video/Audio



There are two ways to delete an image/video/audio:

- Using the **Delete** button, or
- Using Playback Menu Delete settings. See “Delete” on page 62.

## Using the Delete Button



Use the **Delete** button on your camera to delete or mark an image/video/audio clip for deletion.

1. Set the camera to Playback mode.
2. View images/videos/audio clips in Single navigation mode.
3. Use the  or  keys to scroll the display.
4. When the desired image/video/audio clip is displayed on the LCD monitor, press the **Delete** button.
5. A confirmation selection appears on screen.
6. Select **Delete**.



7. Press the **SET** button to delete.
8. The next image is displayed on the LCD monitor. To delete another file, use the ◀ or ▶ keys to scroll through the images/videos/audio clips. Then, repeat steps 4 to 7.
9. To close the Delete function and go back to viewing in single navigation mode, select Cancel.



Locked files cannot be deleted at any time. When you try to delete a locked file, the camera displays “File Locked” message on the LCD monitor.

## Playback Menu

The Playback menu allows you to edit images, records voice memo, and setup playback settings.

To go to Playback Menu:

1. Set the camera to Playback mode.
2. Press  to launch the Playback Menu.
3. Use the ▲ or ▼ keys to move through the menu selections.
4. To select a menu, press ▶ or the **SET** button.
5. Change the submenu settings using the 4-way navigation control.
6. Press the **SET** button to save and apply settings.

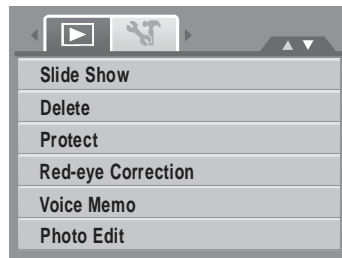

## Slideshow

The Slideshow function allows you to view all stored photos/videos in still image format in a continuous sequence.

To view slideshow:

1. From the Playback menu, select **Slideshow**. The Slideshow menu appears.
2. Set the slideshow settings.
3. Select **Start**, then press the **SET** button to start the slideshow.
4. During slideshow, press the **SET** button to pause slideshow.
5. Use the ▲ or ▼ keys to move through the options. Select whether to **Continue** or **Exit** the slideshow.
6. Press the **SET** button to apply selected option.

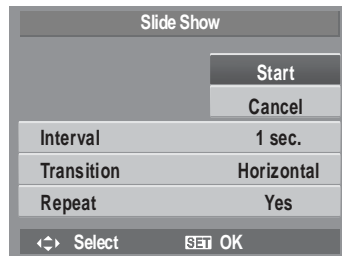

To change slideshow settings:

1. From the Slideshow menu, use the ▲ or ▼ keys to move through the selections.
2. Select Interval setting. Press the ◀ or ▶ keys to adjust. Choose among the available interval settings: 1 sec., 3 sec., 5 sec., and 10 sec.
3. Select Transition setting. Press the ◀ or ▶ keys to adjust. Choose among the available transition settings:
  - Horizontal
  - Shrink
  - Fade
  - Random
4. Select Repeat setting. Press the ◀ or ▶ keys to adjust. Available settings are: Yes, No.

## Delete

The Delete function lets you remove unwanted files in the internal memory or on the memory card. Protected files cannot be erased, to delete, unprotect the file first. See “Protect” on page 65.

To delete a photo/video/audio clip:

1. From the Playback menu, select **Delete**.
2. The Delete submenu is displayed on the LCD monitor. Select available settings:
  - **Single**. Select one file to delete.
  - **Voice Only**. Delete only the attached voice memo, the image is retained in the memory.
  - **Multi**. Select multiple files to delete at the same time.
  - **All**. Delete all files.

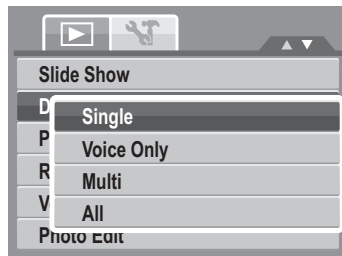

To delete a single file:

1. Select **Single** in the Delete submenu, the images are displayed on the LCD monitor in single navigation mode.
2. Use the ◀ or ▶ keys to scroll the display.
3. When the desired image/video/audio clip is displayed on the LCD monitor, select **Delete**.
4. Press the **SET** button to delete.
5. The next image is displayed on the LCD monitor. To delete another file, use the ◀ or ▶ keys to scroll through the images/videos/audio clips. Repeat steps 3 to 7.
6. To close the Delete function and go back Playback menu, select **Cancel**.



To delete attached voice memo:

1. Set the camera to Playback mode.
2. View images/videos/audio clips in Single navigation mode.
3. Use the ◀ or ▶ keys to scroll until the desired image with voice memo is displayed on the screen.
4. Press  to launch the Playback Menu.
5. Use the ▲ or ▼ keys to move through the Playback menu selections then select **Delete**.
6. From the Delete submenu, select **Voice only**.
7. A confirmation selection appears, select **Delete**.
8. Press the **SET** button to delete the attached voice memo and go back to Playback mode.



The Voice Only submenu is disabled if the current image displayed, at the time you access the Delete menu, does not have any attached voice memo.

To delete multiple files:

1. Select **Multi** in the Delete submenu, the images are displayed in thumbnail view on the LCD monitor.
2. Use the navigation control to move through the files.
3. When the desired image/video/audio clip is highlighted, press the **SET** button to mark image/video/audio clip for deletion.
4. Repeat step 3 until all desired images for deletion are marked.



5. Press the **MENU** button. A confirmation selection appears.
6. Select **Yes** to confirm.
7. Press the **SET** button to delete marked files.

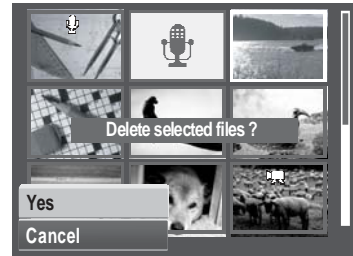

To delete all files:

1. Select **All** in the Delete submenu. A confirmation message appears.
2. Select **Yes**.
3. Press the **SET** button to delete all files.

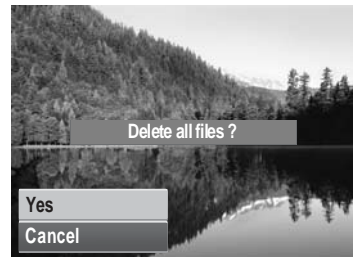

## Protect

The Protect function lets you lock a photo or video to protect it from being modified or accidentally erased. A protected file has a lock icon when viewed on Playback mode.

To protect files:

1. From the Playback menu, select **Protect**.
2. The Protect submenu is displayed on the LCD monitor. Select available settings:
  - **Single**. Select one file to lock.
  - **Multi**. Select multiple files from the thumbnail view to lock.
  - **Lock All**. Lock all files
  - **Unlock All**. Unlock all files.

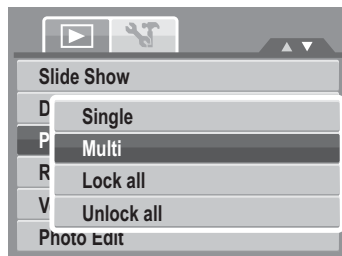

To protect/unprotect a single file:

1. Select **Single** in the Protect submenu, the images are displayed on the LCD monitor in single navigation mode.
2. Use the ◀ or ▶ keys to scroll the display.
3. When the desired file is displayed on the LCD monitor, select **Lock/Unlock**.
4. Press the **SET** button to protect/unprotect the file and go back to Playback mode.



To protect/unprotect multiple files:

1. Select Multi in the Protect submenu, the images are displayed in thumbnail view on the LCD monitor.
2. Use the navigation control to move through the files.
3. When the desired file is highlighted, press the **SET** button to mark/unmark the file clip for protection.



4. Repeat step 3 until all desired files to protect are marked.
5. Press the **MENU** button. A confirmation selection appears.
6. Select **Yes**.
7. Press the **SET** button to lock files and go back to Playback mode.



To protect all files:

1. Select **Lock all** in the Protect submenu. A confirmation message appears.
2. Select **Yes**.
3. Press the **SET** button to delete all files.

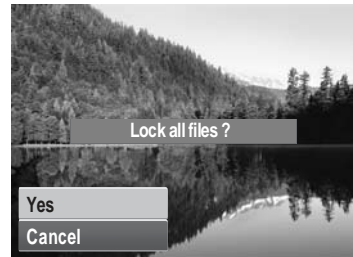

To unlock all files:

1. Select **Unlock all** in the Protect submenu. A confirmation message appears.
2. Select **Yes**.
3. Press the **SET** button to unlock all protected files.





## Red Eye Correction

The Red Eye Correction function is used to reduce red eye in captured images. This function is only available for still images. Red eye correction can be applied to an image several times, but the quality may gradually deteriorate.

To activate Red Eye Correction:

1. Set the camera to Playback mode.
2. Press the ◀ or ▶ keys to scroll and select an image.
3. Press the **MENU** button to launch the Playback menu.
4. Select **Red Eye Correction**.
5. Select **Start**.
6. Press the **SET** button to start correction.



Steps 5 and 6



Step 7

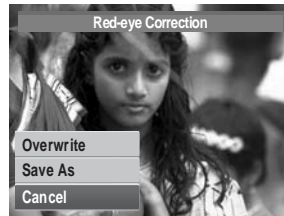

7. After completing Red eye correction, a menu selection appears. Select whether to:
  - **Overwrite.** Save and replace the old file with the new one.
  - **Save As.** Save the new file as a new one.
  - **Cancel.** Cancel red eye correction.
8. Press the **SET** button to save/cancel changes.

## Voice Memo

The Voice Memo function allows you to record and attach a voice memo to a saved image. You can record a maximum of 30 seconds of Voice memo per image. This function is only available in still images.

To record voice memo:

1. Set the camera to Playback mode.
2. Press the ◀ or ▶ keys to scroll and select an image to attach voice memo to.
3. Press the **MENU** button to launch the Playback menu.
4. Select **Voice Memo**.
5. Select **Start**, then press the **SET** button to start recording.

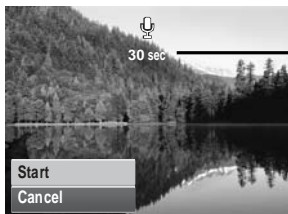

**Time left (n seconds) for recording.**

6. Select **Stop**, then press the **SET** button to stop recording.



When you record voice memo to an image with an existing voice memo, the old recording is automatically changed to the new one.

## Photo Edit

The Photo Edit function lets you edit still images to apply different colors or tones for a more artistic effect. Edited photos in this function is saved as a new file.



To activate Photo Edit:

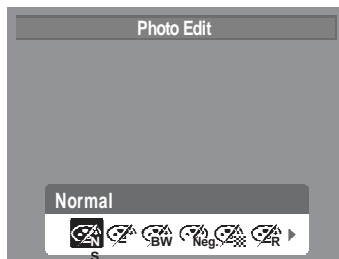





1. Set the camera to Playback mode.
2. Press the ◀ or ▶ keys to scroll and select an image to edit.
3. Press the **MENU** button to launch the Playback menu.
4. Select **Photo Edit**. The Photo Edit submenu appears.



5. Press the ◀ or ▶ keys to scroll and select an option. As you move through the selection, the preview on the LCD monitor changes synchronously.

The succeeding table shows the available settings.

Icon	Item	Description
	Normal	No effect is added to the image.
	Sepia	Image is saved with a sepia tone.

Icon	Item	Description
	B&W	Image is saved in black and white.
	Negative	Image appears to be the opposite of the original image.
	Mosaic	Image is saved with mosaic tiles.
	Vivid Red	Image is saved with reddish tint.
	Vivid Green	Image is saved with greenish tint.
	Vivid Blue	Image is saved with bluish tint.

## Trim

The Trim function allows you to trim an image to another image size. This function is only available for still images.

To trim an image:

1. Set the camera to Playback mode.
2. Use the ◀ or ▶ keys to scroll and select an image to trim.
3. Press the **MENU** button to launch the Playback menu.

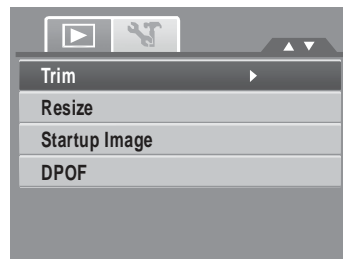

4. Select **Trim**. The Trim screen layout is displayed on the LCD monitor.
5. Use the  control to change size.

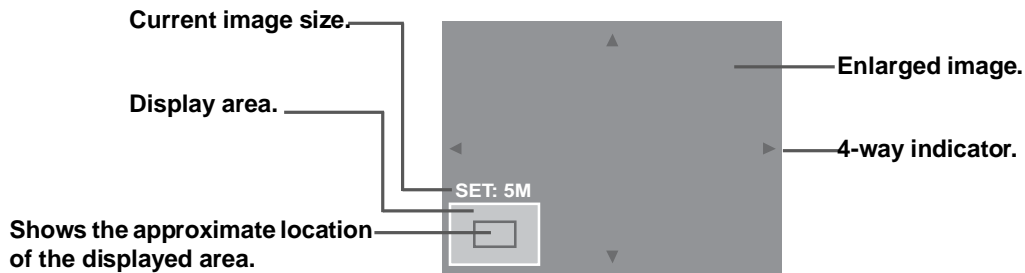

6. Use the navigation controls to move the image.

7. Press the **SET** button to apply changes. A menu selection appears.

8. Select whether to:

- **Overwrite.** Save and replace the old file with the new one.
- **Save As.** Save the new file as a new one.
- **Cancel.** Cancel resize.

9. Press the **SET** button to save/cancel changes.



- Trim function, “3:2”, “16:9” and VGA are not available for photos with image size set to VGA.
- All images will be trimmed in 4:3 ratio regardless of its original image ratio.

## Resize

The Resize function allows you to change the image resolution of large images to smaller ones. This function is only available for still images.

To resize an image:

1. Set the camera to Playback mode.
2. Use the ◀ or ▶ keys to scroll and select an image to resize.
3. Press the **MENU** button to launch the Playback menu.
4. Select **Resize**. The Resize submenu is displayed on the LCD monitor.
5. Select size among: 8M, 5M, 3M, and VGA. Available size settings may vary depending on original image size. Unavailable settings appear as gray icons in Resize submenu.
6. After selecting size, a menu selection appears. Select whether to:
  - **Overwrite**. Save and replace the old file with the new one.
  - **Save As**. Save the new file as a new one.
  - **Cancel**. Cancel resize.
7. Press the **SET** button to save/cancel changes.

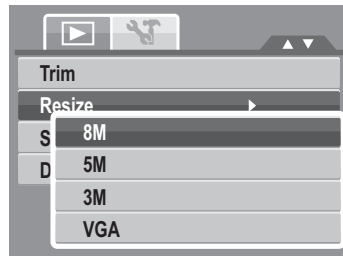

Resize function, "3:2", "16:9" and VGA are not available for photos with image size set to VGA.

## Startup Image

The Startup Image function allows you to setup a startup image when you turn on your camera.

1. Press the **MENU** button to launch the Playback menu.
2. Select **Startup Image**. The menu selection appears.
3. Select options:
  - **System**. Use camera default image.
  - **My Photo**. Use the ◀ or ▶ keys to scroll and select desired image.
  - **Off**. Disable the startup image.
4. Press the **SET** button to apply changes.



The startup image will still be displayed startup even if the selected image was deleted.

## DPOF

The Digital Print Order Format (DPOF) function allows you to mark image in your memory card for printing and allows you to specify the number of copies that you want to print at a later date. When all images to be printed are marked, take the memory card to a digital printing service, or use a DPOF compatible printer.

To set DPOF:

1. Press the **MENU** button to launch the Playback menu.
2. Select **DPOF**. The submenu appears. Available settings are as follows:
  - **Single**. Select a single image to mark.
  - **All**. Mark all images in the memory card.
  - **Reset**. Reset all DPOF settings to initial default settings.

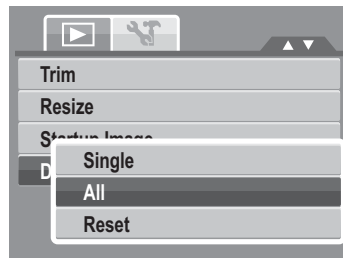

To set DPOF on a single image/all images:

1. Select **Single** or **All** on the DPOF submenu.
2. For single image, use the ◀ or ▶ keys to scroll and select an image to mark for printing.
3. Specify the number of copies. Use the ▲ or ▼ to increase/decrease number.
4. Press the **FUNC** button to toggle between turning on/off the date stamp.
5. Press the **SET** button to save DPOF settings.



To reset DPOF:

1. Select **Reset** on the DPOF submenu. A confirmation message appears.
2. Select **Yes**.
3. Press the **SET** button to reset DPOF settings.



You can specify up to 99 copies for DPOF. If you specify 0 copies, the DPOF setting of that image is automatically disabled.



## PictBridge

The PictBridge function allows you to print images captured by your camera without connecting the camera to a PC. Print images with a PictBridge compatible printer directly.

To activate PictBridge:

Connect your camera to a PictBridge compatible printer using the USB cable. See illustration below.

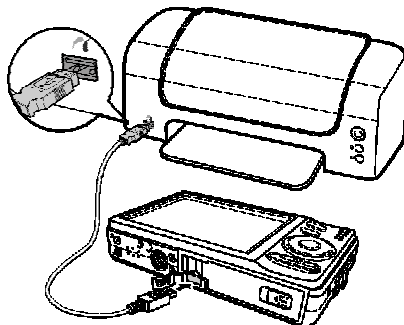

If the printer does not support date stamp, the date stamp function will be disabled in PictBridge.

# Using the Setup Menu

You can access the Setup menu whether you are in Photo/Movie Record or Playback mode. The Setup menu allows you to configure general camera settings.

To go to Setup Menu:

1. Press **[M]** to launch the Record/Playback Menu.
2. In Photo Record or Playback mode, use the ◀ or ▶ keys to change the menu tab to **Setup**  menu. In Movie Record mode, Setup menu is automatically displayed.
3. Use the ▲ or ▼ keys to move through the menu selections.
4. To select an item, press the **SET** button or ▶.
5. Change the submenu settings using the 4-way navigation control.
6. Press the **SET** button to save and apply settings.

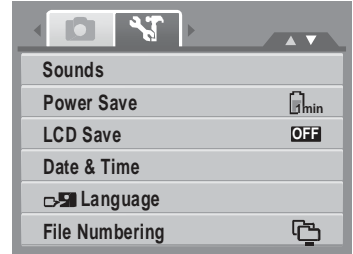

## Setting Sounds

Use the Sound menu functions to control the sounds produced by the camera.

1. From the Settings menu, select **Sounds**.
2. Adjusts sound settings.
3. Press the **SET** button to apply changes.

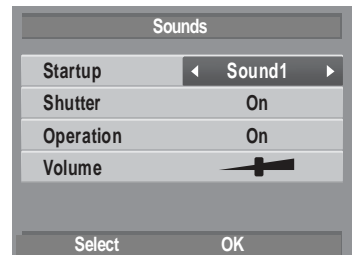

Item	Available Settings	Description
Startup	Sound 1, Sound 2, Sound 3, Off	Selects the startup sound when camera is turned on.
Shutter	On, Off	Enables or disables shutter sound when shutter button is pressed. Shutter sound is not available when recording movies or voice clips.
Operation	On, Off	Enables or disables operation sound.
Volume	0-4	Adjusts volume.

## Setting Power Save

The Power Save function allows you to set an idle time after which the camera automatically sets to sleep mode to save power. After a minute of being in sleep mode, the camera eventually turns off power.

This function is not available in the following instances:

- Recording a movie or audio file
- Playing a slideshow/movie/audio file
- Using the USB connector

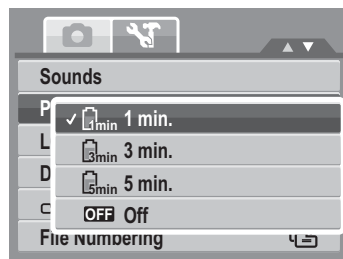

## Setting LCD Save

Enable the LCD Save function to automatically decrease the LCD brightness to conserve battery power. When the camera is idle for 20 seconds, the LCD darkens. Press any button to resume to normal brightness.

- The camera is idle when no buttons are pressed. LCD Save, though enabled, does not function during movie playback, slideshow, and video recording.

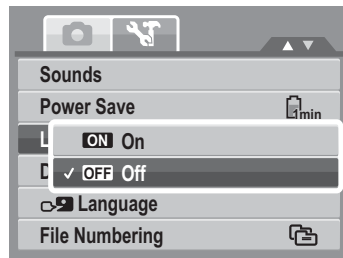

## Setting Date & Time

Use the Date & Time function to set the date and time of your camera. This function is useful in attaching date stamps on captured images. Your camera uses a 24-hour time format.

1. Press the navigation controls to adjust date and time value. By holding down the ▲ or ▼ keys, the numeric values changes continuously.
2. Press the **SET** button to apply changes.

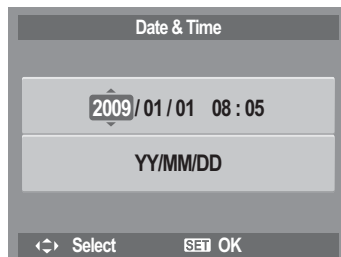

## Setting Language

The Language menu allows you to choose the language of the on screen display (OSD) menu.



- Use the navigation control to scroll through the list and select the desired language.
- Press the **SET** button to confirm and apply settings.



## Setting File Numbering

This function allows you to select the method in which to assign file numbers to images.

Available settings are:

-  **Series**. Assigns number to files in sequence even if the folder is changed.
-  **Reset**. Starts from 0001 each time the folder is changed.

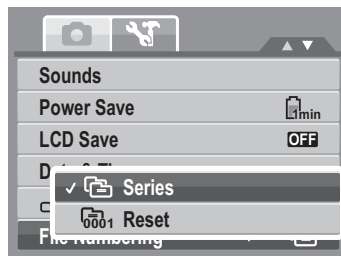

To understand folder and file structure of your camera, see "About Folder and File Names" on page 83.



## Setting TV Out

Use the TV Out function to adjust video output signal to accommodate different regional settings. If TV out is not set correctly, the image may not display properly on TV.

Available settings are:

-  **NTSC**. Applicable in Japan, USA, Canada, Taiwan and others.
-  **PAL**. Applicable in Europe, Asia (excluding Taiwan), Oceania and others.

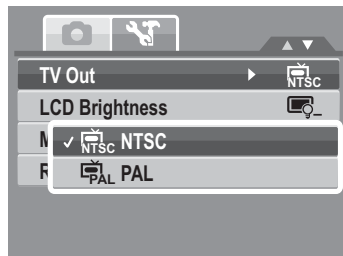

## Setting LCD Brightness

Use the LCD Brightness function to control the LCD brightness.

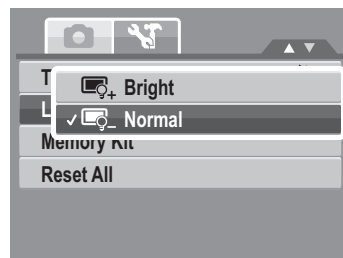

## Setting Memory Kit

Use this function to manage contents of the internal memory or memory card.

Available settings are:

- **Format**. Select to format currently used memory.
- **Copy to Card**. Select to copy all files stored in the internal memory to the memory card.

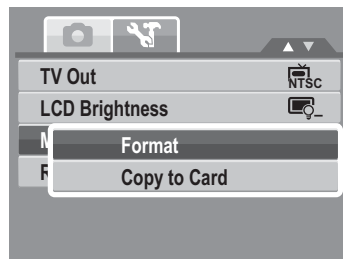



- If there is a memory card inserted in the memory slot, the camera automatically saves all files to the memory card.
- If there is no memory card or the internal memory is empty, the **Copy to Card** function is disabled.

## Reset All

Use this function to reset the camera to its factory settings. However, the following settings are exceptions and not affected by Reset.

- Date and Time
- Language
- TV Out
- Custom White Balance data

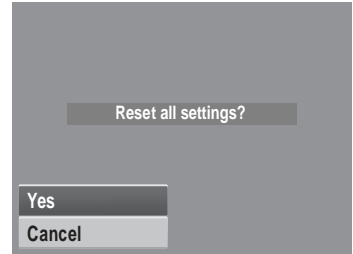

# Making Connections

You can connect your camera to: TV, computer, or a printer.

## Connecting the Camera to a TV

To connect your camera to a TV:

1. Turn on the camera.
2. Set the TV out to match the TV's video out format. See "Setting TV Out" on page 79.
3. Connect the USB/AV 3-in-1 cable to the USB port on the bottom of your camera.
4. Connect the other end of the cable to the TV's AV input port.
5. The LCD monitor turns black and all images and video clips are displayed on the TV.

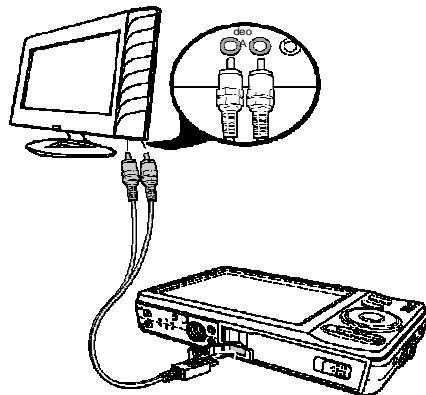

## Connecting the Camera a PC

You can transfer photos, videos and audio files to your PC.

1. Connect the camera to a PC using the USB cable.
2. Turn on the camera.
3. The PC detects the connection. The camera's internal memory and memory card display as removable drives in the file manager. No image is displayed on the LCD monitor.

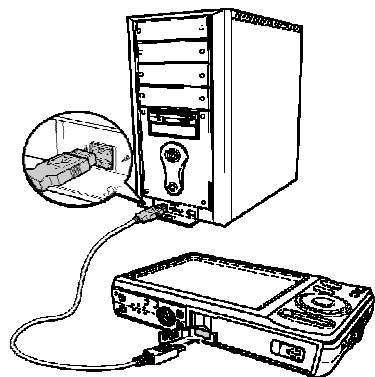

## Connecting the Camera to a Printer

You can print your photos directly using a PictBridge compatible printer.

1. Turn on your camera.
2. Set PictBridge settings.
3. Connect the camera to the printer using the USB cable.

For more details on how to print photos, see “PictBridge” on page 75.

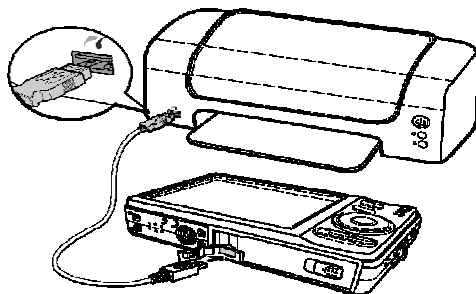



# Appendix

## About Folder and File Names

Your camera automatically creates specific directory of folders in the internal memory cards to organize captured images, videos and audio files.

### Folder Structure

Your camera creates three directory names:

- **DICAM.** All captured images, videos and audio files are stored in this folder except for files recorded using the Auction or YouTube® mode.
- **\_AUCT.** Captured images using the Auction mode are saved in this folder.
- **\_UTUBE.** Captured videos using the YouTube® mode are saved in this folder.

Folder names begin with a 3-digit number from 100 to 999 and followed by “DICAM” or “\_AUCT” or “\_UTUBE”. Each folder holds up to 9999 files. If new files are saved, a new folder named in sequence will be automatically created.

### File Naming

File names begin with “DSCI” and followed by a 4-digit number that increases in sequence. File numbering starts from 0001 when a new folder is created.

If the highest folder number is 999 and the highest file number exceeds 9999, the camera will display the warning message “Folder cannot be created.” When this happens, try one of the following ways:

- Reset the file number. See “Setting File Numbering” on page 78
- Plug in a new memory card.



Do not change the folder and file names in the memory card using your PC. It may be unable to playback the data using the camera.

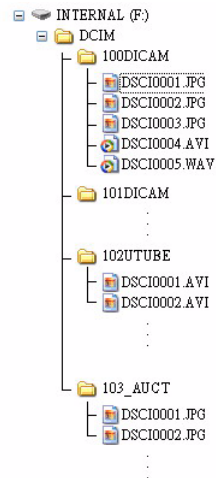

# Troubleshooting

Problem	Cause and/or Action
Camera does not turn on.	The batteries may be exhausted. Charge or replace the batteries.
Camera turns off automatically.	Press any button except the Power button to turn on the camera.
LCD turns blank.	Press any button except the Power button to turn on the LCD.
Empty battery icon is displayed on the LCD, then the camera turns off.	Batteries are exhausted, please replace or recharge.
LCD screen displays 'No image'.	The image file on the memory card. Image file format may not be supported.
LCD screen displays 'Not available for this file'.	Function is only available for specific file types. File format is not supported.
LCD screen displays 'Memory full'.	Memory card is full. Replace the memory card with a new one or delete unnecessary images.
LCD screen displays 'File locked'	This file is locked. Unlock the file. See "Protect" on page 65.
LCD screen displays 'Card locked'.	The memory card is protected. Remove the card and slide the write-protect switch to its unlock position.
LCD screen displays 'Format error'.	The memory card is protected. Remove the card and slide the write-protect switch to its unlock position.

Problem	Cause and/or Action
LCD screen displays 'Copy error'.	<p>The memory card is protected. Remove the card and slide the write-protect switch to its unlock position.</p> <p>The memory card is full. Replace card or delete unnecessary files.</p>
No image displays on the TV screen	Incorrect TV-out type was selected. Set the correct TV-out type to match your TV system.
The lens got stuck up.	Do not force the lens to go back. The type of the battery used may be incorrect or the battery power level is too low. Change the battery or charge the battery before using the camera.

# Specifications

Sensor	10 megapixel, Type: 1/2.3
Lens	Focal length: f = 6.2 - 18.6 mm, 3x optical zoom, 5x digital zoom
LCD Monitor	2.7" color LCD
Focusing Range	Normal: 80cm - Infinity Macro Wide: 5cm - 100cm Tele: 30 - 100cm
Aperture	F = 3.0 - 5.6
Shutter	Type: Mechanical and Electronic Shutter Speed: Auto: 1 - 1/2,000 sec. Manual: 8 - 1/2,000 sec. Night: 8 - 1/2,000 sec. Fireworks: 2 sec.
File Format	Still Image: EXIF 2.2 compatible format (JPEG compression) Video: AVI (MJPEG) Audio: WAV
Resolution (Still image)	10M (3648 X 2736), 3:2 (3648 X 2432), 8M (3264 X 2448), 5M (2592 X 1944), 3M (2048 X 1536), 16:9 (1920 x 1080), VGA (640 X 480)
Resolution (Video)	16:9, 640, 320, For Internet
Scene Mode	Auto, Program, Aperture Priority, Shutter Priority, Manual Exposure, Intelligent Scene, Portrait, Landscape, Sunset, Backlight, Kids, Night Scene, Fireworks, Snow, Sports, Party, Candlelight, Night Portrait, Soft Skin, Soft Flowing Water, Food, Building, Text, Auction, Smile Detection, Blink Detection, Pre-Composition, Love Portrait, Movie, Voice Rec

Sensitivity	Auto / 100 / 200 / 400 / 800 / 1600 / 3200 (3M, 16:9<2M>,VGA) / 6400 (1024 x 760)
White Balance	Auto, Daylight, Cloudy, Tungsten, Fluorescent 1, Fluorescent 2, Custom
Exposure Control	-2EV to + 2EV (1/3EV steps)
Metering	Multi, Center, Spot
Driver Mode	10 sec., 2 sec., Double, Burst, Off
Flash	Auto, Red-eye Reduction, Forced On, Slow Sync, Forced Off
Effect (Preview)	Normal, Vivid, Sepia, B&W, Vivid Red, Vivid Green, Vivid Blue
Photo Edit	Normal, B&W, Sepia, Negative, Mosaic, Vivid Red, Vivid Green, Vivid Blue
Storage	Internal memory: 32MB flash memory External memory: SD (up to 4GB), SDHC card (up to 32GB guaranteed)
OSD Language	English, French, Spanish, German, Italian, Russian, Portuguese, Brazil Portuguese, Dutch, Turkish, Polish, Hungarian, Romanian, Czech, Bulgarian, Croatian, Slovak, Slovenian, Greek, Swedish, Norwegian, Finnish, Danish, Arabic, Indonesian, Malay, Thai, Japanese, Korean, Simplified Chinese, Traditional Chinese
Interface	USB / AV OUT
TV system	NTSC, PAL
Battery	Li-ion battery
Operating Temperature	0° C - 40° C
Operating Humidity	5% - 85%
Microphone	Built-in

Speaker	Built-in
Dimensions	90.1 X 56.8 X 18.8 mm
Weight	105 g

## Customer care

More information on the complete AgfaPhoto digital camera product range can be found under [www.plawa.com](http://www.plawa.com) / [www.plawausa.com](http://www.plawausa.com)

**Service & Repair (USA/ Canada):**

732 537 6004

[www.plawausa.com](http://www.plawausa.com)

**Online Service (USA/ Canada):**

[support-apdc@plawausa.com](mailto:support-apdc@plawausa.com)

**Service & Repair Hotline (EU):**

00800 752 921 00 (from a landline only)

**Online Service / International contact:**

[support-apdc@plawa.com](mailto:support-apdc@plawa.com)

**Service & Support Hotline (Germany):**

0900 1000 042 (1.49 Euro/ min. from a German landline only)

Manufactured by

plawa-feinwerktechnik GmbH & Co. KG

Bleichereistraße 18

73066 Uhingen

Germany

AgfaPhoto is used under license of Agfa-Gevaert NV & Co. KG or Agfa-Gevaert NV. Neither Agfa-Gevaert NV & Co KG nor Agfa-Gevaert NV manufacture this product or provide any product warranty or support. For service, support and warranty information, contact the distributor or manufacturer.

# Disposal of Waste Equipment by Users in Private Households in the European Union



This symbol on the product or on its packaging indicates that this product must not be disposed of with your other household waste. Instead, it is your responsibility to dispose of your waste equipment by handing it over to a designated collection point for the recycling of waste electrical and electronic equipment. The separate collection and recycling of your waste equipment at the time of disposal will help to conserve natural resources and ensure that it is recycled in a manner that protects human health and the environment. For more information about where you can drop off your waste equipment for recycling, please contact your local city office, your household waste disposal service or the shop where you purchased the product.

## FCC Compliance and Advisory

This device complies with Part 15 of the FCC Rules. Operation is subject to the following two conditions: 1.) this device may not cause harmful interference, and 2.) this device must accept any interference received, including interference that may cause unsatisfactory operation. This equipment has been tested and found to comply with the limits for a Class B peripheral, pursuant to Part 15 of the FCC Rules. These limits are designed to provide reasonable protection against harmful interference in a residential installation. This equipment generates, uses, and can radiate radio frequency energy and, if not installed and used in accordance with the instructions, may cause harmful interference to radio communication. However, there is no guarantee that interference will not occur in a particular installation. If this equipment does cause harmful interference to radio or television reception, which can be determined by turning the equipment off and on, the user is encouraged to try to correct the interference by one or more of the following measures.

- Reorient or relocate the receiving antenna.
- Increase the separation between the equipment and receiver.
- Connect the equipment to an outlet on a circuit different from that to which the receiver is connected.
- Consult the dealer or an experienced radio/TV technician for help.

Any changes or modifications not expressly approved by the party responsible for compliance could void the user's authority to operate the equipment. When shielded interface cables have been provided with the product or when specified additional components or accessories have elsewhere been designated to be used with the installation of the product, they must be used in order to ensure compliance with FCC regulations.

Warning: A shielded-type power cord is required in order to meet FCC emission limits and to prevent interference to radio and television reception. Use only shielded cable to connect I/O devices to this equipment. Any changes or modifications not expressly approved by the manufacturer may void your warranty and service agreement.

## Declaration of Conformity

We herewith confirm the following designated product: AgfaPhoto digital camera OPTIMA 100 has been tested and found to comply with the requirements set up in the council directive on the approximation of the law of members' states relating to the EMC Directive. For the evaluation regarding to the electromagnet compatibility, the following standards were applied:

EN 55022: 2006 + A1: 2007 Class B	IEC 61000-4-4 2004
EN 55024: 1998+A1: 2001+A2: 2003	IEC 61000-4-5 Edition 2.0: 2005
EN 61000-3-2: 2006	IEC 61000-4-6: Edition 2.2: 2006
EN 61000-3-3: 1995 + A1: 2001 + A2: 2005	IEC 61000-4-8 Edition 1.1: 2001-03
IEC 61000-4-2: Edition 1.2: 2001-04	IEC 61000-4-11 Second Edition: 2004
IEC 61000-4-3 Edition 3.0: 2006	AS/NZS CISPR 22:2006

The device is marked with CE logo.





AgfaPhoto is used under license of Agfa-Gevaert NV & Co. KG or Agfa-Gevaert NV. Neither Agfa-Gevaert NV & Co. KG nor Agfa-Gevaert NV manufacture this product or provide any product warranty or support. For service, support and warranty information, contact the distributor or manufacturer. For service, support and warranty information, contact the distributor or manufacturer. All other brands and product names are registered trademarks of their respective owners. Product design and technical features can be changed without notice.

AgfaPhoto Holding GmbH, [www.agfaphoto.com](http://www.agfaphoto.com)  
Manufactured by plawa-feinwerktechnik GmbH & Co. KG, [www.plawa.com](http://www.plawa.com)